

ROME MINE POWER CABLE - TYPE MP-GC

Rome-EPR, Tape Shield, Hypalon Jacket, 8000 Volts

APPLICATION: Shielded high voltage power distribution cable suitable for installation in boreholes, shafts, horizontal runs in underground entries, aerial suspension on insulators and other semi-permanent mining and industrial feeder installations. For use in circuits rated 8000 volts, maximum conductor temperature 90°C.

STANDARDS: Conforms to ICEA S-75-381 (NEMA WC58).

CONSTRUCTION: Three insulated power conductors each consisting of stranded annealed copper, conductor shield, Rome-EPR ethylene-propylene rubber insulation, extruded insulation shield, metallic tape shield. Two uninsulated grounding conductors of stranded annealed tinned copper. One #8 AWG 7-strand annealed uncoated copper ground check conductor (#10 AWG for size 6 cable) insulated with yellow insulation. Three insulated and shielded power conductors cabled together with the ground check conductor in the valley between the black and white power conductors, and one grounding conductor in each of the other two valleys. Fillers to make cable round, tape over assembly and overall Hypalon jacket vulcanized in a metal mold. Embossed marking molded as an integral part of the jacket, including the inscription P-105 to indicate full compliance with State of Pennsylvania Safety Codes.

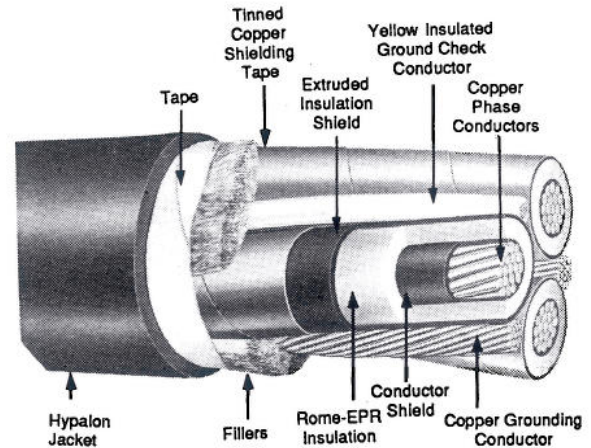

Power Conductor			Grounding Conductor		Jacket Thickness Mils	Nominal Diameter Inches	Approx. Net Weight Lb./1000 Ft.	Ampacity*	
Size AWG or kcmil	No. of Strands	Insulation Thickness Mils	Size AWG	No. of Strands				20°C Ambient	40°C Ambient
8000 VOLTS, 100% INSULATION LEVEL									
6	7	115	10	7	110	1.33	1050	110	93
4	7	115	8	7	110	1.43	1265	144	122
2	7	115	6	7	110	1.55	1690	188	159
1	19	115	5	7	110	1.65	2020	217	184
1/0	19	115	4	7	140	1.75	2330	249	211
2/0	19	115	3	7	140	1.88	2875	286	243
3/0	19	115	2	19	140	2.00	3325	329	279
4/0	19	115	1	19	140	2.12	4325	378	321
250	37	115	1/0	19	140	2.25	4810	418	355
350	37	115	2/0	19	140	2.46	6430	513	435
500	37	115	4/0	19	140	2.75	8640	632	536

*AMPACITY based upon continuous duty at 90°C conductor temperature, ambient temperature as indicated, cable in free air.

Information on this sheet subject to change without notice.

Specification

ROME MINE POWER CABLE - TYPE MP-GC

Rome-EPR, Tape Shield, Hypalon Jacket, 8000 Volts

1. SCOPE

- 1.1 This specification describes three-conductor Type MP-GC power cable with Rome-EPR (ethylene-propylene-rubber) insulation for use in circuits rated 8000 volts at a maximum conductor temperature of 90°C. Cables are intended for use as power distribution cable suitable for installation in boreholes, shafts, horizontal runs in underground entries, aerial suspension on insulators and other semi-permanent mining and industrial feeder installations.

2. STANDARDS

- 2.1 The following standard shall form a part of this specification:
2.1.1 ICEA Pub. No. S-75-381 for Portable and Power Feeder Cables for Use in Mines and Similar Applications (NEMA WC58).

3. CONDUCTORS

- 3.1 Class B stranded, annealed, uncoated copper per Part 2 of ICEA.

4. CONDUCTOR SHIELDING

- 4.1 Conductors shall employ conductor shielding meeting the requirements of Par. 4.3.2 of ICEA.

5. INSULATION

- 5.1 A homogeneous wall of Rome-EPR insulation shall be extruded over the covered conductor. The average thickness shall be as specified in Table 4-3 of ICEA. The minimum thickness shall be not less than 90 percent of the specified average thickness.
5.2 Physical and electrical properties of the insulation shall be in accordance with Par. 4.4 of ICEA.

6. SHIELDING

- 6.1 An extruded conducting thermosetting insulation shield shall be applied over the insulation in accordance with Par. 4.5 of ICEA.
6.2 A tinned copper tape shield shall be applied over the extruded insulation shield in accordance with the requirements of Par. 4.5 of ICEA.

7. CIRCUIT IDENTIFICATION

- 7.1 A color coded tape (black, white, red) applied under the metallic shielding tape shall provide circuit identification on each power conductor in accordance with Par. 4.6 of ICEA.

8. GROUNDING CONDUCTORS

- 8.1 The grounding conductors shall be stranded annealed copper of not less than the size and number of wires as shown in Table 4.1 of ICEA for the corresponding power conductor sizes.

9. GROUND CHECK CONDUCTOR

- 9.1 The minimum ground check conductor shall be given in Table 4-1 of ICEA for the corresponding power conductor sizes.
9.2 The conductor shall have a yellow insulation meeting the requirements of Par. 4.4.2 of ICEA and shall be located between the black and white phase conductors.

10. ASSEMBLY

- 10.1 The conductors shall be twisted together with a left hand lay meeting the requirements of Par. 4.7 of ICEA. Suitable fillers shall be used to produce an essentially round cross-section in the completed cable.
10.2 A binder tape shall be helically applied over the cable assembly.

11. JACKET

- 11.1 A thermosetting jacket shall be extruded over the assembly in accordance with Par. 4.8 of ICEA.
11.2 The jacket shall be a heavy-duty Hypalon meeting the requirements of Table 3-4 of ICEA.

12. COMPLETED CABLE

- 12.1 The nominal outside diameter shall be in accordance with Table 4-3 of ICEA. The outside diameter of the completed cable shall be within plus 8 and minus 5 percent of the nominal value.

13. SURFACE MARKINGS

- 13.1 All cable shall have an embossed print legend showing manufacturer, cable type, size, voltage, and State of Pennsylvania Approval Number.

14. TESTS

- 14.1 Cable shall be tested in accordance with Par. 4.10 of ICEA.